

Material: iglidur® I150-PF

1. General

The material iglidur® I150-PF, developed by igus®, was developed and tested solely for the “Fused-Deposition-Modeling” (FDM) manufacturing method.

For beginners iglidur® I150 is the most preferred type, since it is the easiest Tribofilament to process. It is the only iglidur® Tribofilament, which can be processed without a heated bed.

2) Data for the processing

The optimum processing parameters depend on the various print parameters and on the 3D printers that are used. Therefore only ranges of values can be specified here (see the figure on page. 2):

- (1) Nozzle temperature: ~250°C
- (2) Bed temperature: 20-60 °C
- (3) Print speed: ~ 50 mm/s
- (4) Bottom layer speed: ~ 50 mm/s
- (5) Layer height: 0.1 to 0.3 mm
- (6) Shell-thickness (6.1) to nozzle-diameter (6.2) ratio: >1
- (7) Avoid cooling by fan
- (8) The enclosure of the printer in a case is advantageous
- (9) Bed-surface:
 - igus® adhesive foil for the printing-bed (necessary at printers without heated bed)
 - available in 203*203 mm; article-number: PF-01-0203-0203
 - available in 254*228 mm; article-number: PF-01-0254-0228
 - Glue-stick on glass
 - “3D-Lac” on glass or carbon plates

3) Further processing instructions:

Upon processing, a good ventilation of the room should always be ensured. Alternatively, suction systems or 3D-printers equipped with built-in filters can be used. In addition, appropriate protective equipment should be used when handling the hot molten mass.

The material should not be heated beyond 280 °C. When heated beyond 300 °C, hazardous decomposition products are generated.

Based on the supplier’s experience and the information provided by the supplier, the product has no adverse health effects if properly handled and used in accordance with the intended purpose.

Image: 3D-printer

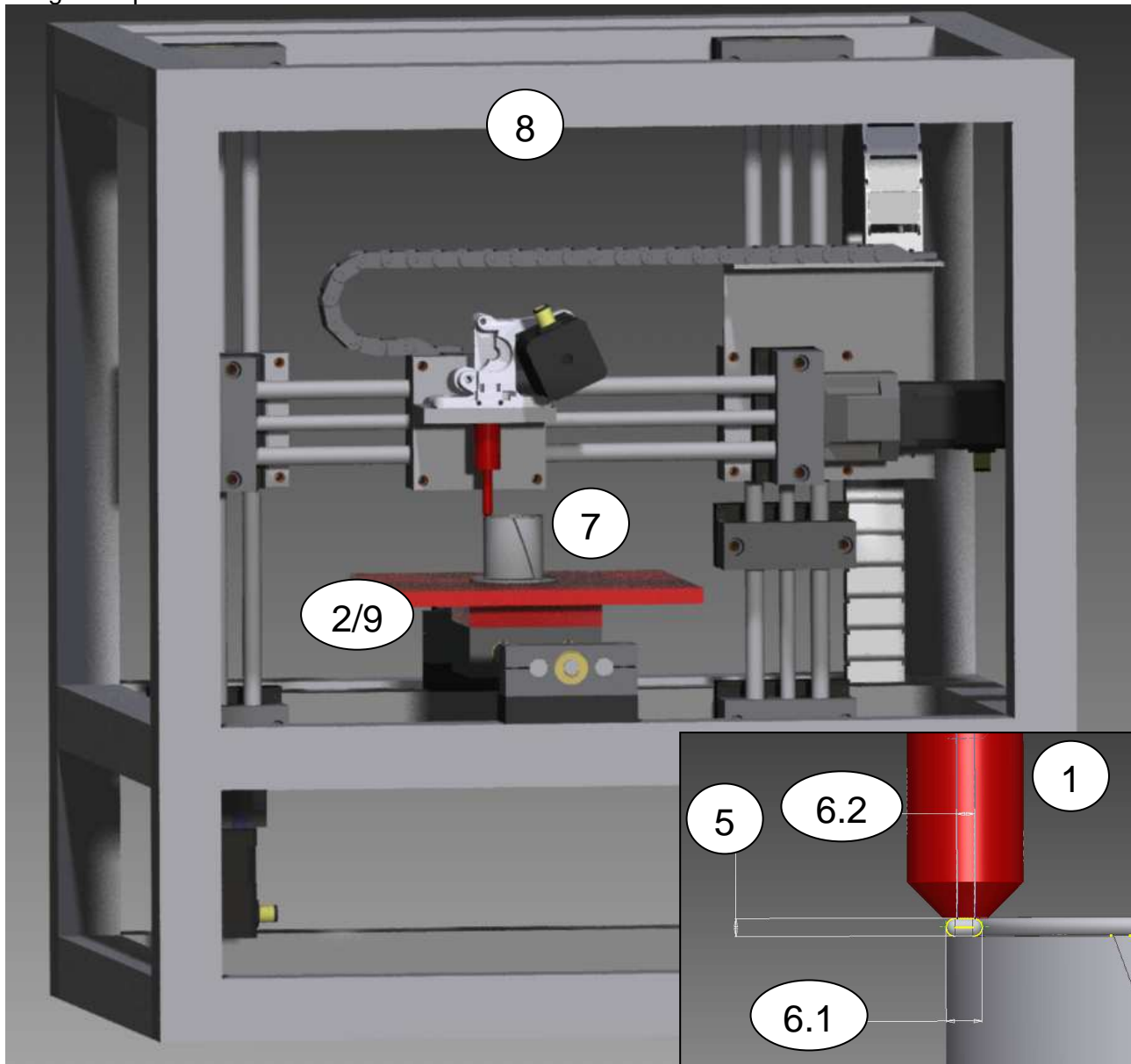

4) FAQ

Where do I find the processing instructions for iglidur I150 tribofilament?

Following the link on our website: www.igus.eu/I150-PF-instructions

Do I need a heated bed (platform) on my printer?

Yes, for most of the Tribofilament materials a heated bed is necessary, only Iglidur[®] I150 can be processed without heated buildplate (then igus adhesive film is needed).

Does igus[®] offer a filament diameter size of 2,85 mm?

The 3 mm filament is designed to be suitable for printers requiring 2,85 mm.

Where can I get the igus® adhesive foil for the printing-bed?

Following the link on our website: [http://www.igus.eu/Adhesive film for print bed](http://www.igus.eu/Adhesive_film_for_print_bed)

Which Tribofilament is the easiest to process?

Iglidur® I150 is by far the most easily to process Tribofilament. It can even be processed without heated buildplate (then igus adhesive foil is necessary).

Iglidur® I180 is suited for more advanced users, because more conditions need to be considered (e.g. enclosed printer, switched off fan).

Iglidur® I170, Iglidur® J260, and Iglidur® C210 are suited for experts; since they are harder to process.

The printed part does not stick to the print bed, what can I do?

1. Check the distance between nozzle and print bed. Re-level the platform when necessary.
2. Did you use the correct printsurface? Is the printer enclosed? Check page 1, point 2

The adhesion between printbed and part is too high. How to reduce the adhesion?

Reduce the print-bed-temperature.

Does a running fan (part-cooling) help with the print quality?

All iglidur Tribofilaments are preferably printed with switched off fan.

I experience problems at the beginning of a print. How can I improve this issue?

With every new print start, it is possible that the nozzle gets clogged due to remaining material debris stored too long at high temperatures within the hotend. We recommend to make sure the nozzle is free and clean and it does have a nice and even material flow. With Iglidur® I150 we recommend to increase the retraction length and speed, so that previous issue is prevented. When retracted at the end of a build, no material is stored within the hotend.

Furthermore check if filament grinding occurred and adjust the material feeding pressure accordingly.