

## PolyFlex™ TPU95-HF

PolyFlex™ TPU95-HF, created from Covestro's Addigy® family, is a TPU with high flow properties making it ideal for high speed printing. Combined with its UV resistance, PolyFlex™ TPU95-HF unlocks new applications for flexible materials in manufacturing.

### Physical Properties

Property	Testing method	Typical value
Density	ASTM D792 (ISO 1183, GB/T 1033)	1.16 (g/cm <sup>3</sup> at 21.5 °C)
Melt index	185 °C, 1.2 kg	9.3 (g/10 min)

Tested with 3D printed specimen of 100% infill

### Mechanical Properties

Property	Testing method	Typical value
100% modulus (X-Y)	ASTM D638 (ISO 527, GB/T 1040)	13.24 ± 0.29 (MPa)
Tensile strength (X-Y)	ASTM D638 (ISO 527, GB/T 1040)	23.11 ± 0.63 (MPa)
Elongation at break (X-Y)	ASTM D638 (ISO 527, GB/T 1040)	462.3 ± 21.1 (%)
Shore hardness	ASTM D2240 (ISO 7619, GB/T 31)	95A

All testing specimens were printed under the following conditions:  
 nozzle temperature = 210 °C, printing speed = 45 mm/s, build plate temperature = 50 °C, infill = 100%  
 All specimens were conditioned at room temperature for 24h prior to testing

### Recommended printing conditions

Parameter	
Nozzle temperature	200 - 220 (°C)
Build Surface material	BuildTak®, Glass
Build surface treatment	Applying PVA and PVP glue to the build surface
Build plate temperature	25 - 50 (°C)
Cooling fan	Turned on from second layer
Printing speed	40-100 (mm/s)
Retraction distance	1-3 (mm)
Retraction speed	60 (mm/s)
Recommended environmental temperature	Room temperature - 45 (°C)
Threshold overhang angle	40 (°)

Based on 0.4 mm nozzle and Simplify 3D v.4.1. Printing conditions may vary with different nozzle diameters

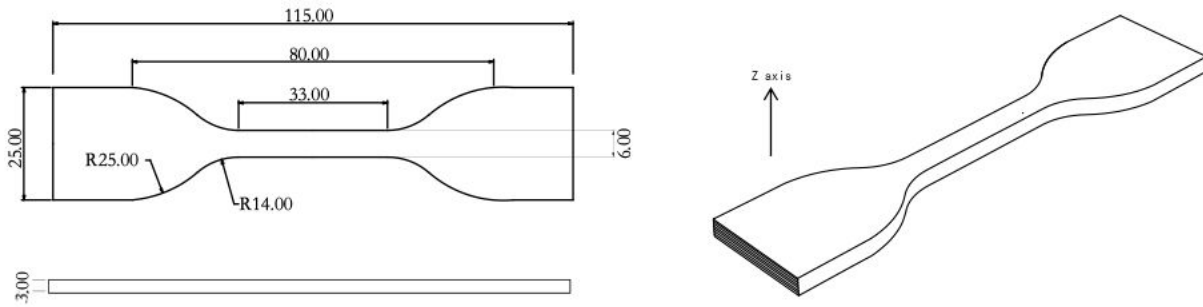

Tensile testing specimen; **ASTM D638 (ISO 527, GB/T 1040)**

## Disclaimer:

The typical values presented in this data sheet are intended for reference and comparison purposes only. They should not be used for design specifications or quality control purposes. Actual values may vary significantly with printing conditions. End-use performance of printed parts depends not only on materials, but also on part design, environmental conditions, printing conditions, etc. Product specifications are subject to change without notice.

Each user is responsible for determining the safety, lawfulness, technical suitability, and disposal/recycling practices of Polymaker materials for the intended application. Polymaker makes no warranty of any kind, unless announced separately, to the fitness for any use or application. Polymaker shall not be made liable for any damage, injury or loss induced from the use of Polymaker materials in any application.