

# LCD PID Temperature Controllers



## TX Series PRODUCT MANUAL

**For your safety, read and follow the considerations written in the instruction manual, other manuals and Autonics website.**

The specifications, dimensions, etc are subject to change without notice for product improvement. Some models may be discontinued without notice.

### Features

- 50ms high-speed sampling rate and  $\pm 0.3\%$  display accuracy
- Large LCD display with easy-to-read white PV characters
- Switch between current output and SSR drive output
- SSR drive output (SSRP function) control options: ON/OFF control, cycle control, phase control
- Communication output model available: RS485 (Modbus RTU)
- Parameter configuration via PC (RS485 communication): DAQMaster software included (comprehensive device management software)
- Compact, space-saving design with 45 mm depth: 30% rear-length size reduction compared to similar-sized (48 × 48 mm) models from Autonics  
Terminal protection cover sold separately: RSA-COVER

\*Korea Patent Registration 30-2020-0020300, Korea Patent Registration 10-1651262, U.S.A. Patent Registration 10281339, Japan Patent Registration 6603317, China Patent Registration ZL201580039398.2, Germany Patent Application 112015003239.8

\*Korea Design Registration 30-0999138

### Safety Considerations

- Observe all 'Safety Considerations' for safe and proper operation to avoid hazards.
- **⚠** symbol indicates caution due to special circumstances in which hazards may occur.

**⚠ Warning** Failure to follow instructions may result in serious injury or death

- 01. Fail-safe device must be installed when using the unit with machinery that may cause serious injury or substantial economic loss.** (e.g. nuclear power control, medical equipment, ships, vehicles, railways, aircraft, combustion apparatus, safety equipment, crime/disaster prevention devices, etc.)  
Failure to follow this instruction may result in personal injury, economic loss or fire.
- 02. Do not use the unit in the place where flammable/explosive/corrosive gas, high humidity, direct sunlight, radiant heat, vibration, impact or salinity may be present.**  
Failure to follow this instruction may result in explosion or fire.
- 03. Install on a device panel to use.**  
Failure to follow this instruction may result in fire or electric shock.
- 04. Do not connect, repair, or inspect the unit while connected to a power source.**  
Failure to follow this instruction may result in fire or electric shock.
- 05. Check 'Connections' before wiring.**  
Failure to follow this instruction may result in fire.
- 06. Do not disassemble or modify the unit.**  
Failure to follow this instruction may result in fire or electric shock.

**⚠ Caution** Failure to follow instructions may result in injury or product damage

- 01. When connecting the power input and relay output, use AWG 20 (0.50 mm<sup>2</sup>) cable or over, and tighten the terminal screw with a tightening torque of 0.74 to 0.90 N m.**  
**When connecting the sensor input and communication cable without dedicated cable, use AWG 28 to 16 cable and tighten the terminal screw with a tightening torque of 0.74 to 0.90 N m.**  
Failure to follow this instruction may result in fire or malfunction due to contact failure.
- 02. Use the unit within the rated specifications.**  
Failure to follow this instruction may result in fire or product damage
- 03. Use a dry cloth to clean the unit, and do not use water or organic solvent.**  
Failure to follow this instruction may result in fire or electric shock.
- 04. Keep the product away from metal chip, dust, and wire residue which flow into the unit.**  
Failure to follow this instruction may result in fire or product damage.

### Cautions during Use

- Follow instructions in 'Cautions during Use'. Otherwise, it may cause unexpected accidents.
- Check the polarity of the terminals before wiring the temperature sensor. For RTD temperature sensor, wire it as 3-wire type, using cables in same thickness and length. For thermocouple (TC) temperature sensor, use the designated compensation wire for extending wire.
- Keep away from high voltage lines or power lines to prevent inductive noise. In case installing power line and input signal line closely, use line filter or varistor at power line and shielded wire at input signal line. Do not use near the equipment which generates strong magnetic force or high frequency noise.

- Do not apply excessive power when connecting or disconnecting the connectors of the product.
- Install a power switch or circuit breaker in the easily accessible place for supplying or disconnecting the power.
- Do not use the unit for other purpose (e.g. voltmeter, ammeter), but temperature controller.
- When changing the input sensor, turn off the power first before changing. After changing the input sensor, modify the value of the corresponding parameter.
- Do not overlapping communication line and power line. Use twisted pair wire for communication line and connect ferrite bead at each end of line to reduce the effect of external noise.
- Make a required space around the unit for radiation of heat. For accurate temperature measurement, warm up the unit over 20 min after turning on the power.
- Make sure that power supply voltage reaches to the rated voltage within 2 sec after supplying power.
- Do not wire to terminals which are not used.
- This unit may be used in the following environments.
  - Indoors (in the environment condition rated in 'Specifications')
  - Altitude Max. 2,000 m
  - Pollution degree 2
  - Installation category II

## Ordering Information

This is only for reference, the actual product does not support all combinations. For selecting the specified model, follow the Autonics website .

**T X ① ② - ③ ④ ⑤**

**① Display digits**  
4: 4 digit

### ② Size

S: DIN W 48 × H 48 mm  
M: DIN W 72 × H 72 mm  
H: DIN W 48 × H 96 mm  
L: DIN W 96 × H 96 mm

### ③ Option in/output

1: Alarm 1  
2: Alarm 1 + Alarm 2  
A: Alarm 1 + Alarm 2 + PV transmission  
B: Alarm output 1 + Alarm output 2 + RS485

### ④ Power supply

4: 100 - 240 VAC~

### ⑤ Control output

R: Relay  
S: SSR drive  
C: Selectable current or SSR drive output

## Product Components

- Product (+ bracket)
- Instruction manual

## Manual

For proper use of the product, refer to the manuals and be sure to follow the safety considerations in the manuals. Download the manuals from the Autonics website.

## Software

Download the installation file and the manuals from the Autonics website.

### ■ DAQMaster

DAQMaster is comprehensive device management program. It is available for parameter setting, monitoring.

## Sold Separately

- Terminal protection cover: RSA / RMA / RHA / RLA-COVER

## Specifications

Series		TX Series
Power supply		100 - 240 VAC~ 50/60 Hz
Permissible voltage range		90 to 110 % of rated voltage
Power consumption		≤ 8 VA
Sampling period		50 ms
Input specification		Refer to 'Input Type and Using Range'.
Control output	Relay	250 VAC~ 3 A, 30 VDC= 3 A, 1a
	SSR	TX4S: 12 VDC= ±2 V, ≤ 20 mA TX4M/H/L: 13 VDC= ±3 V, ≤ 20 mA
	Current	DC 4-20 mA or DC 0-20 mA (parameter), Load resistance: ≤ 500 Ω
Alarm output	Relay	AL1/2: 250 VAC~ 3 A 1a
Option output	PV transmission	DC 4 - 20 mA (Load resistance: ≤ 500 Ω, Output Accuracy: ±0.3% F.S.)
	RS485 Comm.	Modbus RTU
Display type		11 Segment (White, Green, Yellow), LCD type
Control type	Heating, Cooling	ON/OFF, P, PI, PD, PID Control
Hysteresis		1 to 100 (0.1 to 50.0) °C/°F
Proportional band (P)		0.1 to 999.9 °C/°F
Integral time (I)		0 to 9,999 sec
Derivative time (D)		0 to 9,999 sec
Control cycle (T)		0.5 to 120.0 sec
Manual reset		0.0 to 100.0%
Relay life cycle	Mechanical	≥ 5,000,000 operations
	Electrical	≥ 200,000 operations (resistance load: 250 VAC~ 3 A)
Dielectric strength		Between the charging part and the case: 3,000 VAC~ 50/60 Hz for 1 min
Vibration		0.75 mm amplitude at frequency 5 to 55Hz in each X, Y, Z direction for 2 hours
Insulation resistance		≥ 100 MΩ (500 VDC= megger)
Noise immunity		±2 kV square shaped noise (pulse width 1 μs) by noise simulator R-phase, S-phase
Memory retention		≈ 10 years (non-volatile semiconductor memory type)
Ambient temperature		-10 to 50 °C, storage: -20 to 60 °C (no freezing or condensation)
Ambient humidity		35 to 85%RH, storage: 35 to 85%RH (no freezing or condensation)
Protection structure		IP50 (Front panel, IEC standards)
Insulation type		Double or reinforced insulation (mark: □, dielectric strength between primary circuit and secondary circuit: 3 kV)
Certification		CE UK & IAS ENEC
Unit weight (packaged)		• TX4S: ≈ 87 g (≈ 146 g)      • TX4M: ≈ 143 g (≈ 233 g) • TX4H: ≈ 133 g (≈ 214 g)      • TX4L: ≈ 206 g (≈ 290 g)

01) When using the unit at low temperature (below 0°C), display cycle is slow.

## Communication Interface

### ■ RS485

Comm. protocol	Modbus RTU
Application standard	EIA RS485 compliance with
Maximum connection	31 units (address: 01 to 127)
Synchronous method	Asynchronous
Comm. method	Two-wire half duplex
Comm. effective range	≤ 800 m
Comm. speed	2,400 / 4,800 / 9,600 (default) / 19,200 / 38,400 bps (parameter)
Response time	5 to 99 ms (default: 20 ms)
Start bit	1 bit (fixed)
Data bit	8 bit (fixed)
Parity bit	None (default), Odd, Even
Stop bit	1 bit, 2 bit (default)

## Input Type and Using Range

The setting range of some parameters is limited when using the decimal point display.

Input type	Decimal point	Display	Using range (°C)	Using range (°F)	
Thermo-couple	K (CA)	1	K E R H	-50 to 1,200	-58 to 2,192
		0.1	K E R L	-50.0 to 999.9	-58.0 to 999.9
	J (IC)	1	J I E H	-30 to 800	-22 to 1,472
		0.1	J I E L	-30.0 to 800.0	-22.0 to 999.9
	L (IC)	1	L I E H	-40 to 800	-40 to 1,472
		0.1	L I E L	-40.0 to 800.0	-40.0 to 999.9
T (CC)	1	T E E H	-50 to 400	-58 to 752	
	0.1	T E E L	-50.0 to 400.0	-58.0 to 752.0	
R	1	R P R	0 to 1,700	32 to 3,092	
S (PR)	1	S P R	0 to 1,700	32 to 3,092	
RTD	Cu50 Ω	1	C U S H	-50 to 200	-58 to 392
		0.1	C U S L	-50.0 to 200.0	-58.0 to 392.0
	D Pt100 Ω	1	d P E H	-100 to 400	-148 to 752
	0.1	d P E L	-100.0 to 400.0	-148.0 to 752.0	

## Display accuracy

Input type	Using temperature	Display accuracy
Thermocouple RTD	At room temperature (23°C ±5°C)	(PV ±0.3% or ±1°C higher one) ±1-digit • Thermocouple R, S below 200°C: (PV ±0.5% or ±3°C higher one) ±1-digit Over 200°C: (PV ±0.5% or ±2°C higher one) ±1digit • Thermocouple L, RTD Cu50 Ω: (PV ±0.5% or ±2°C higher one) ±1-digit
	Out of room temperature range	(PV ±0.5% or ±2°C higher one) ±1-digit • Thermocouple R, S: (PV ±1.0% or ±5°C higher one) ±1digit • Thermocouple L, RTD Cu50 Ω: (PV ±0.5% or ±3°C higher one) ±1digit

## Unit Descriptions

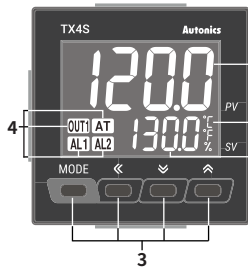

- PV display part (White)**
  - Run mode: displays PV (Present value)
  - Setting mode: displays parameter name
- SV display part (Green)**
  - Run mode: displays SV (Setting value)
  - Setting mode: displays parameter setting value
- Input key**

Display	Name
[MODE]	Mode key
[←], [↓], [→], [↑]	Setting value control key

### 4. Indicator

Display	Name	Description
°C, %, °F	Unit	Displays selected unit (parameter)
AT	Auto tuning	Flashes during auto tuning every 1 sec
OUT1	Control output	Turns ON when control output 1 is ON
AL1/2	Alarm output	Turns ON when each alarm output is ON

- PC loader port:** For connecting communication converter (sold separately).

## Errors

Display	Description	Troubleshooting
o P E n	Flashes when input sensor is disconnected or sensor is not connected.	Check input sensor status.
H H H H	Flashes when PV is higher than input range.	When input is within the rated input range, this display disappears.
L L L L	Flashes when PV is lower than input range.	

## Dimensions

- Unit: mm, For the detailed drawings, follow the Autonics website.
- Below is based on TX4S Series.

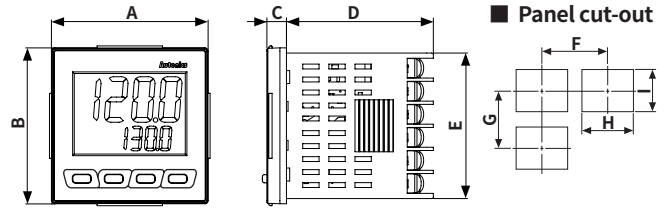

	Body					Panel cut-out			
	A	B	C	D	E	F	G	H	I
TX4S	48	48	6	45	44.8	≥ 65	≥ 65	45 <sup>+0.6</sup> <sub>0</sub>	45 <sup>+0.6</sup> <sub>0</sub>
TX4M	72	72	6	45	67.5	≥ 90	≥ 90	68 <sup>+0.7</sup> <sub>0</sub>	68 <sup>+0.7</sup> <sub>0</sub>
TX4H	48	96	6	45	91.5	≥ 65	≥ 115	45 <sup>+0.6</sup> <sub>0</sub>	92 <sup>+0.8</sup> <sub>0</sub>
TX4L	96	96	6	45	91.5	≥ 115	≥ 115	92 <sup>+0.8</sup> <sub>0</sub>	92 <sup>+0.8</sup> <sub>0</sub>

## Bracket

### TX4S

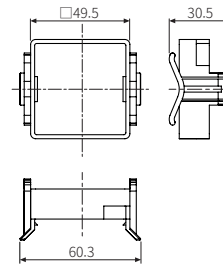

### Other series

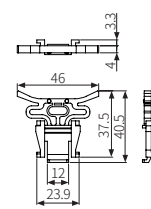

## Installation Method

### TX4S

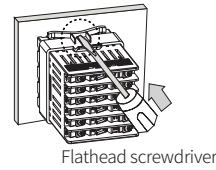

Flathead screwdriver

### Other series

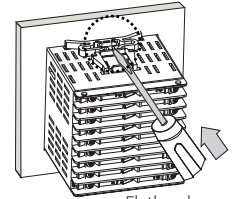

Flathead screwdriver

Insert the unit into a panel, fasten the bracket by pushing with tools with a flathead screwdriver.

## Connections

- Shaded terminals are standard model.

### TX4S

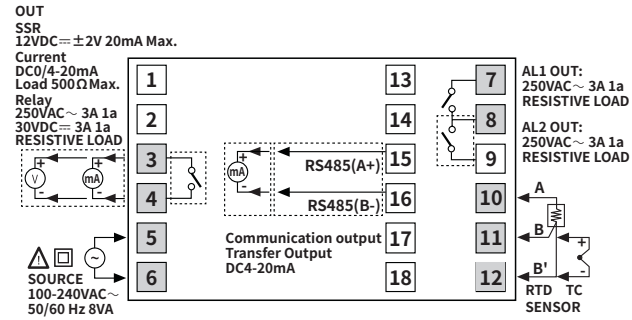

### TX4M

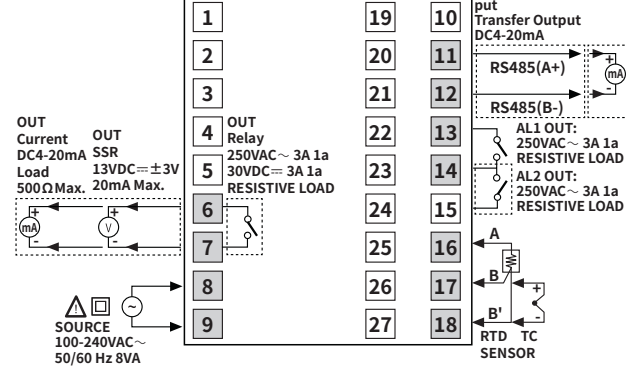

### TX4H/L

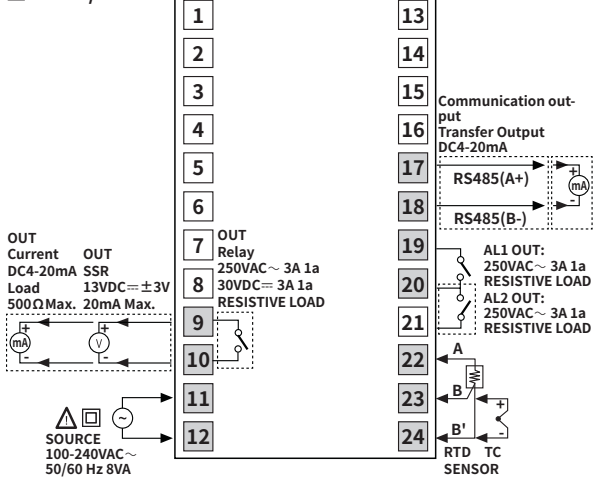

## Mode Setting

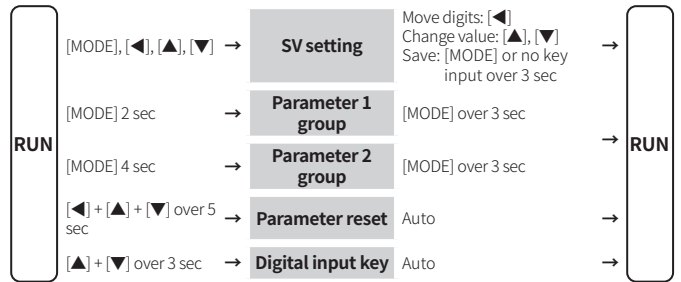

## Parameter Setting

- Some parameters are activated/deactivated depending on the model or setting of other parameters. Refer to the descriptions of each item.
- [MODE] key: Move to next item after saving / Return to RUN mode after saving ( $\geq 3$  sec) / Return to previous parameter after saving (within 1 sec returning to RUN mode)
- [◀] key: Select parameter / Move digits / Return to the upper level without saving ( $\geq 2$  sec) / Return to RUN mode without saving ( $\geq 3$  sec)
- [▲], [▼] key: Select parameter / Change setting value
- Return to the upper level without saving when there is no key input for more than 30 seconds.
- The range in parentheses '(')' is the setting range when the set value of the 'input specification' parameter is used with one decimal point.
- Recommended parameter setting sequence: Parameter 2 group → Parameter 1 group → SV setting mode

### Parameter 1 group

Parameter	Display	Default	Setting range	Condition
1-1 AL1 alarm temperature	AL 1	125.0	Deviation alarm: -F.S. to F.S. °C/°F Absolute value alarm: Within input range	2-16/19 AL1/2 alarm Operation: AM1 to AM6, HBA
1-2 AL2 alarm temperature	AL 2	125.0	[Alarm output2 model] Same as 1-1 AL1 alarm temperature	
1-3 Auto tuning	AL E	0 F F	OFF: Stop, ON: Execution	-
1-4 Proportional band	P	10.0	0.1 to 999.9 °C/°F	
1-5 Integral time	I	24.0	0 (OFF) to 9,999 sec	2-8 Control type: PID
1-6 Derivative time	D	4.9	0 (OFF) to 9,999 sec	
1-7 Manual reset	RESE	50.0	0.0 to 100.0%	2-8 Control type: PID & 1-5 Integral time: 0
1-8 Hysteresis	HYS	2	1 to 100 (0.1 to 50.0) °C/°F	2-8 Control type: ONOF

## Crimp Terminal Specifications

- Unit: mm, Use the crimp terminal of follow shape.

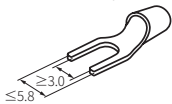

Fork crimp terminal

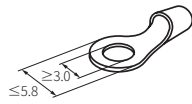

Round crimp terminal

## Parameter 2 group

Parameter	Display	Default	Setting range	Condition
2-1 Input specification <sup>(1)</sup>	I N - t	# C R H	Refer to 'Input Type and Using Range'	-
2-2 Temperature unit <sup>(1)</sup>	U N I t	° C	°C, °F	-
2-3 Input correction	I N - b	0	-999 to 999 (-199.9 to 999.9) °C/°F	-
2-4 Input digital filter	M A V : F	0.1	0.1 to 120.0 sec	-
2-5 SV low limit <sup>(2)</sup>	L - S V	- 5 0	Within '2-1 Input specification: using range' L-SV ≤ H-SV - 1-digit °C/°F	-
2-6 SV high limit <sup>(2)</sup>	H - S V	1 2 0 0	H-SV ≥ L-SV + 1-digit °C/°F	-
2-7 Control output mode	o - F t	H E A t	HEAT: Heating, COOL: Cooling	-
2-8 Control type <sup>(3)</sup>	C - M d	P I d	PID, ONOF: ON/OFF	-
2-9 Control output	o U t	C U R R	[Selectable current or SSR drive output model] CURR: Current, SSR	-
2-10 SSR drive output type	S S R M	S t N d	[SSR drive output model] STND, CYCL, PHAS	-
2-11 Current output range	o M R	4 - 2 0	4-20: 4-20 mA, 0-20: 0-20 mA	2-9 Control output: CURR
2-12 Control cycle	t	2 0 0	0.5 to 120.0 sec	2-8 Control type: PID or 2-10 SSR drive output type: STND
2-13 AL1 alarm operation	AL - 1	AM 1 R	<input type="checkbox"/> AM0: Off <input type="checkbox"/> AM1: Deviation high limit alarm <input type="checkbox"/> AM2: Deviation low limit alarm <input type="checkbox"/> AM3: Deviation high, low limit alarm <input type="checkbox"/> AM4: Deviation high, low reverse alarm <input type="checkbox"/> AM5: Absolute value high limit alarm <input type="checkbox"/> AM6: Absolute value low limit alarm <input type="checkbox"/> SBA: Sensor break alarm <input type="checkbox"/> LBA: Loop break alarm (LBA)	-
2-14 AL1 alarm option		<input type="checkbox"/> A: Standard alarm <input type="checkbox"/> B: Alarm latch <input type="checkbox"/> C: Standby <input type="checkbox"/> D: Alarm latch and standby sequence 1 <input type="checkbox"/> E: Standby <input type="checkbox"/> F: Alarm latch and standby sequence 2 • Enter to option setting: Press [◀] key in 2-13 AL-1 alarm operation.	-	
2-15 AL2 alarm operation	AL - 2	AM 2 R	[Alarm output2 model]	-
2-16 AL2 alarm option			Same as '2-13/14 AL1 alarm operation/option'	-
2-17 Alarm output hysteresis	A H Y S	1	1 to 100 (0.1 to 50.0) °C/°F	2-13/14 AL1/2 alarm operation: AM1 to 6
2-18 LBA time	L B A t	0	0 (OFF) to 9,999 sec or auto <sup>(4)</sup>	2-13/14 AL1/2 alarm operation: LBA
2-19 LBA band	L B A b	2	0 (OFF) to 999 (0.0 to 999.9) °C/°F or auto <sup>(5)</sup>	2-13/14 AL1/2 alarm operation: LBA & 2-18 LBA time: > 0
2-20 Transmission output low limit	F S - L	- 5 0	[PV transmission output model] Refer to 'Input Type and Using Range'	-
2-21 Transmission output high limit	F S - H	1 2 0 0		-
2-22 Comm. address	A d R S	1	[Communication output model] 1 to 127	-
2-23 Comm. speed	b P S	9 6	[Communication output model] 24, 48, 96, 192, 384 (×100) bps	-
2-24 Comm. parity bit	P R R y	N o N E	[Communication output model] NONE, EVEN, ODD	-
2-25 Comm. stop bit	S t P	2	[Communication output model] 1, 2 bit	-
2-26 Response time	R S H t	2 0	[Communication output model] 5 to 99 ms	-
2-27 Comm. write	C o M M	E N A	[Communication output model] EN:A: Enable, DIS:A: Disable	-
2-28 Digital input key	d i - k	S t o P	STOP: Stop control output, AL,RE: Alarm reset, AT*: Execute auto tuning, OFF	*2-8 Control type: PID
2-29 Sensor error, MV	E R M V	0 0	0.0: OFF, 100.0: ON	2-8 Control type: ONOF
2-30 Lock	L o C	o F F	OFF LOC1: Lock parameter 2 group LOC2: Lock parameter 1/2 group LOC3: Lock parameter 1/2 group, SV setting	2-8 Control type: PID

01) Below parameters are initialized when the setting value is changed.

- Parameter 1 group: AL1/2 alarm temperature,  
- Parameter 2 group: Input correction, SV high/low limit, LBA band, Alarm output Hysteresis

02) If SV is lower/higher than low/high limit when the value is changed, SV is changed to the low/high limit value.

03) When changing the value from PID to ONOF, each value of following parameter is changed.  
2-28 Digital input key: OFF, 2-29 Sensor error, MV: 0.0 (Setting value is lower than 100.0)

04) After auto tuning, the range is set as twice of the integral time automatically. If the previous setting value is outside of the range automatically set, it is set to the nearest Max. or Min. value of the range.

05) After auto tuning, the range is set as 10% of the proportion band automatically. If the previous setting value is outside of the range automatically set, it is set to the nearest Max. or Min value of the range.

## Function: Alarm

000.0

Alarm operation Alarm option

Set both alarm operation and alarm option by combining. Each alarm operates individually in two alarm output models. When the current temperature is out of alarm range, alarm clears automatically.

## Operation

• H: Alarm output hysteresis

Name	Alarm operation	Description
-	-	No alarm output
Deviation high limit		If deviation between PV and SV as high-limit is higher than set value of deviation temperature, the alarm output will be ON.
Deviation low limit		If deviation between PV and SV as low limit is higher than set value of deviation temperature, the alarm output will be ON.
Deviation high, low limit		If deviation between PV and SV as high/low-limit is higher than set value of deviation temperature, the alarm output will be ON.
Deviation high, low limit reverse		If deviation between PV and SV as high/low-limit is lower than set value of deviation temperature, the alarm output will be OFF.
Absolute value high limit		If PV is higher than the absolute value, the output will be ON.
Absolute value low limit		If PV is lower than the absolute value, the output will be ON.
Sensor break	-	It will be ON when it detects sensor disconnection.
Loop break	-	It will be ON when it detects loop disconnection.

## Option

Name	Description	Condition of re-apply
Standard alarm	If it is an alarm condition, alarm output is ON. If it is a clear alarm condition, alarm output is OFF.	-
Alarm latch	If it is an alarm condition, alarm output is ON and maintains ON status.	-
Standby sequence 1	First alarm condition is ignored and from second alarm condition, standard alarm operates. When power is supplied and it is an alarm condition, this first alarm condition is ignored and from the second alarm condition, standard alarm operates.	Power ON
Alarm latch and standby sequence 1	If it is an alarm condition, it operates both alarm latch and standby sequence. When power is supplied and it is an alarm condition, this first alarm condition is ignored and from the second 1 alarm condition, alarm latch operates.	
Standby sequence 2	First alarm condition is ignored and from second alarm condition, standard alarm operates. When re-applied standby sequence and if it is alarm condition, alarm output does not turn ON. After clearing alarm condition, standard alarm operates.	Power ON, change SV, change alarm temperature / operation or change STOP to RUN mode
Alarm latch and standby sequence 2	Basic operation is same as alarm latch and standby sequence 1. It operates not only by power ON/OFF, but also alarm set value, or alarm option changing. When re-applied standby sequence and if it is alarm condition, alarm output does not turn ON. After clearing alarm condition, alarm latch operates.	

## Sold Separately: Terminal Protection Cover

• Unit: mm

**RSA-COVER: DIN W48 × H48**

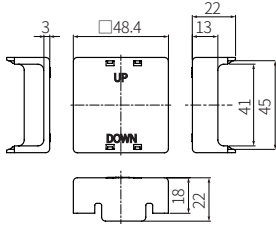

**RMA-COVER: DIN W72 × H72**

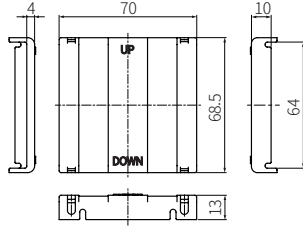

**RHA-COVER: DIN W48 × H96**

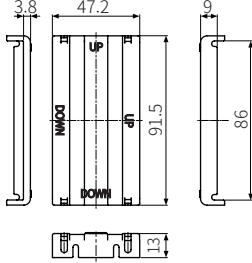

**RLA-COVER: DIN W96 × H96**

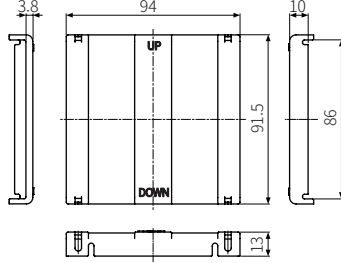

## Segment Table

The segments displayed on the product indicate the following meanings. It may differ depending on the product.

7 Segment				11 Segment				12 Segment				16 Segment			
0	0	l	l	0	0	l	l	0	0	l	l	0	0	l	l
1	1	∩	J	1	1	∩	J	1	1	∩	J	1	1	∩	J
2	2	∩	K	2	2	∩	K	2	2	∩	K	2	2	∩	K
3	3	∩	L	3	3	∩	L	3	3	∩	L	3	3	∩	L
4	4	∩	M	4	4	∩	M	4	4	∩	M	4	4	∩	M
5	5	∩	N	5	5	∩	N	5	5	∩	N	5	5	∩	N
6	6	∩	O	6	6	∩	O	6	6	∩	O	6	6	∩	O
7	7	∩	P	7	7	∩	P	7	7	∩	P	7	7	∩	P
8	8	∩	Q	8	8	∩	Q	8	8	∩	Q	8	8	∩	Q
9	9	∩	R	9	9	∩	R	9	9	∩	R	9	9	∩	R
A	A	∩	S	A	A	∩	S	A	A	∩	S	A	A	∩	S
b	B	∩	T	b	B	∩	T	b	B	∩	T	b	B	∩	T
c	C	∩	U	c	C	∩	U	c	C	∩	U	c	C	∩	U
d	D	∩	V	d	D	∩	V	d	D	∩	V	d	D	∩	V
E	E	∩	W	E	E	∩	W	E	E	∩	W	E	E	∩	W
F	F	∩	X	F	F	∩	X	F	F	∩	X	F	F	∩	X
G	G	∩	Y	G	G	∩	Y	G	G	∩	Y	G	G	∩	Y
H	H	∩	Z	H	H	∩	Z	H	H	∩	Z	H	H	∩	Z